

Radial-Werkzeughalter Form B8 Überkopf links, lang

Radial toolholders form B8 overhead left, long

Porte-outils radials forme B8 inversé gauche, long

DIN ISO 10889-1
(DIN 69880)



Verwendung:

Vorwiegend für Außenbearbeitung.
Zum Plan Einstechen.

Application:

Mainly for external machining.
For face machining.

Application:

Principalement pour usinage extérieur.
Pour carottage.

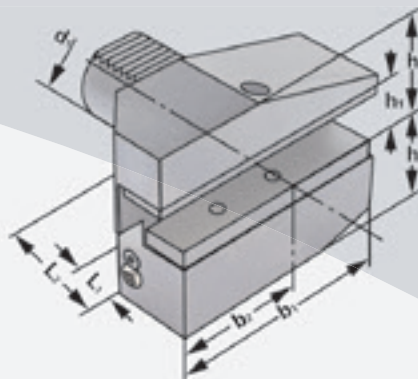

DIN ISO 10889
(DIN 69880)

B8

Bestell-Nr. Order no. Référence	Abmessung Size Dimension	d ₁	b ₁	b ₂	b ₃	L ₁	L ₂	h ₁	h ₅	h ₆
169.38.12	B8 – 16 × 12 × 24	16	58	39	5	13	24	12	20	22
209.38.16	B8 – 20 × 16 × 30	20	75	50	7	16	30	16	30	25
259.38.16	B8 – 25 × 16 × 30	25	75	50	7	16	30	16	30	25
309.38.20	B8 – 30 × 20 × 40	30	100	65	10	22	40	20	38	35
409.38.25	B8 – 40 × 25 × 44	40	118	75,5	12,5	22	44	25	48	42,5
509.38.32	B8 – 50 × 32 × 55	50	130	80	16	30	55	32	60	50

Ausführung:

Version:

Version:

Mit einstellbarer Kugelspritzdüse und Unterlegplatte

With adjustable spray nozzle and shim

Avec gicleur ajustable et semelle

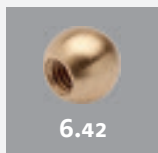

6.42